

# Electric Adaptive Grippers

## EAG2-73105 2-Finger

EAG is an electric 2-finger adaptive gripper that is equipped with two symmetrically articulated fingers.

### Advantages

- Slim body with one installation positions
- Grip control: force and position adjustment
- Quick open/close time with speed adjustment
- Grip feedback and part detection: gripper status can be read at the PLC/Controller and visualized on the unit via LED's
- Plug and play: mechanical and software interface for major cobot manufacturers
- Multiple communication modes: the gripper supports Modbus RTU protocol and IO mode control. Other protocols such as USB and ETHERNET can be implemented through a protocol converter.
- Grip actuation via embedded controller.
- Brake locking mechanism.

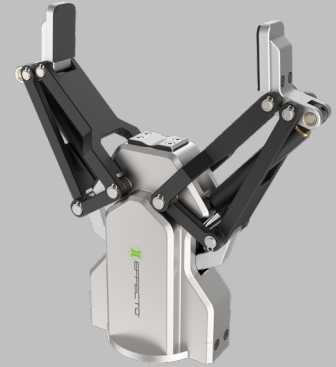

## SPECIFICATIONS

Model	Stroke	Gripping Force per Jaw	Total Gripping Force	Opening/Closing Time	Nominal Voltage	Nominal Current	Max Current	Repeatability (Positioning)	Recommended Workpiece Weight*	Weight (fingers excluded)
<b>EAG2-73105</b>	145 mm 5.71 in	35 - 105 N 7.87 - 23.60 lb	70 - 210 N 15.74 - 47.21 lb	0.7 / 0.7 s	24 V DC $\pm$ 10%	0.8 A	1.50 A	$\pm$ 0.03 mm $\pm$ 0.001 in	2.00 kg 4.41 lb	1.30 kg 2.87 lb

\* Recommended workpiece weight depends on the shape of the part, the material and friction of the contact surface and the acceleration of the motion.

Communication Interface **Standard: Modbus RTU (RS485), Digital I/O**  
**Optional: TCP/IP, USB2.0, CAN2.0A, PROFINET, EtherCAT**

IP Protection Class **IP 54**  
Noise Emission (Sound Pressure)  $\leq$  **40 dB(A) in any direction**  
Recommended operating environment **0-40 °C (32-104 °F), < 85% RH**

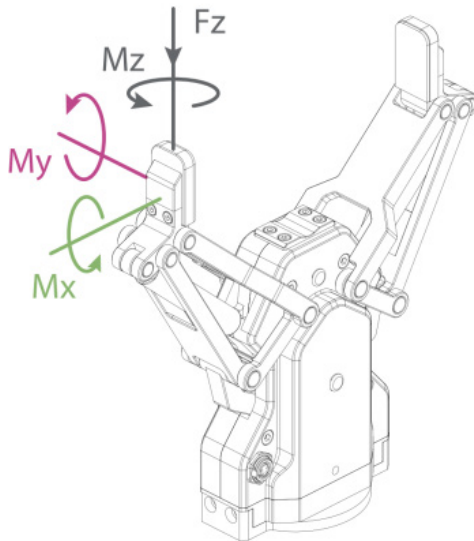

### Allowable vertical load (static)

Fz 300 N (67.44 lb)

### Allowable moment (static)

Mx 1.95 Nm (17.26 in-lb)

My 1.95 Nm (17.26 in-lb)

Mz 1.95 Nm (17.26 in-lb)

# PRODUCT INFORMATION

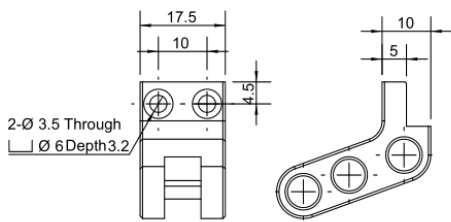
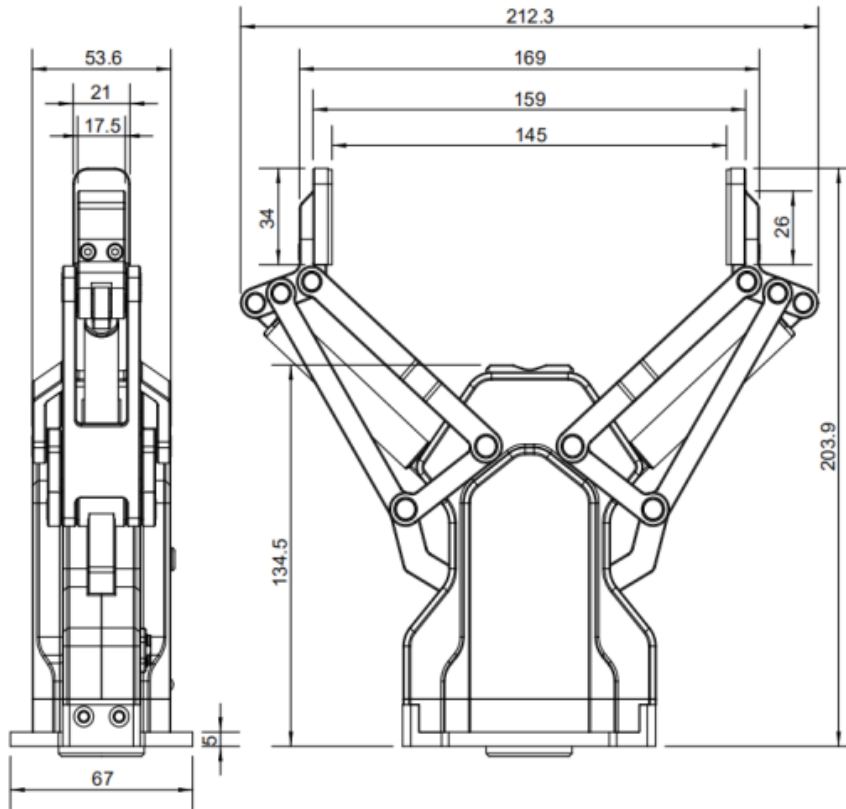

■ Custom fingers mounting size

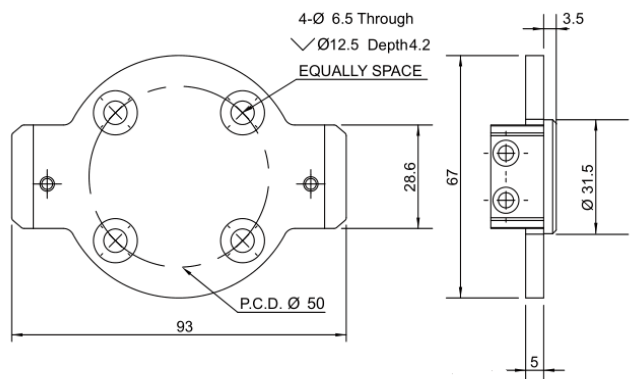
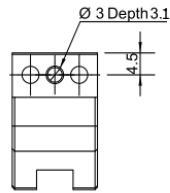

■ Conform to ISO 9409-1-50-4-M6 standard flange



**Applied Robotics Inc.**  
 648 Saratoga Road, Glenville, NY 12302 USA  
 Tel. +1 518 384 1000  
[www.appliedrobotics.com](http://www.appliedrobotics.com)  
[info@appliedrobotics.com](mailto:info@appliedrobotics.com)

