

# Flexible Smart Gripper™

## FSG-2, FSG-4, FSG-2e, and FSG-4e

The Flexible Smart Gripper™ (FSG) is a fully electrically actuated gripper with flexible, soft bodied fingers for handling objects of varying size, shape, and weight.

### Advantages:

- Fully electric
- Programmable Open/Close Finger Position settings
- Patented, FDA compliant silicone fingers
  - Allows for soft, flexible gripping of delicate objects
  - Flexible in gripping direction and rigid in all other degrees of freedom
- Enhanced Intelligence version
  - Part Confirmation
  - Force Control
- Compatible with collaborative robots



## SPECIFICATIONS

Model	Number of Fingers	Rated Payload	Gripper Weight	Maximum Finger Opening at the Tip	Open/Close Speed	Maximum Current (Idle)	Maximum Current (Load)	Maximum Current (Instantaneous)
		kg (lb)	kg (lb)	mm(in)	mm/s (in/s)	A	A	A
FSG-2	2	1.5 (3.3)	0.8 (1.8)	175 (6.9)	1450 (57)	0.03	2	3
FSG-4	4	1.5 (3.3)	1.3 (2.9)	195 (7.7)	1450 (57)	0.08	3	5
FSG-2e	2	1.5 (3.3)	0.8 (1.8)	175 (6.9)	1450 (57)	0.03	2	3
FSG-4e	4	1.5 (3.3)	1.3 (2.9)	195 (7.7)	1450 (57)	0.08	3	5

Rated Voltage: **15 VDC – 25 VDC**

Operating Temperature: **5 - 60 °C (40 - 140 °F)**

Noise Emissions (Sound Pressure): **≤ 70 dB(A) in any direction**

## PATENTED FLEXIBLE FINGER



The Flexible Smart Gripper™ (FSG) allows for the picking and placing of a multitude of shapes and sizes due to its patented, FDA compliant silicone fingers, actuated by a fully electric system. The ability to rotate in the Roll degree of freedom, while keeping rigid in the Pitch and the Yaw degrees of freedom, allows for dependable, soft, and flexible gripping of delicate objects.

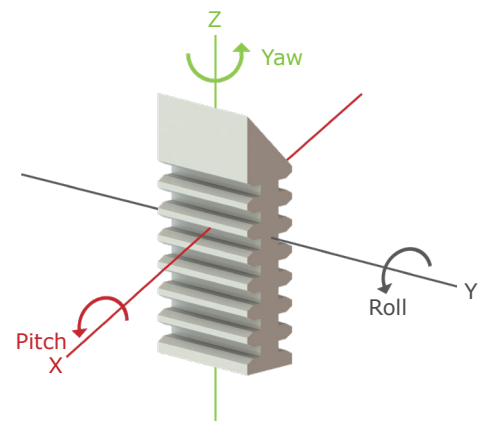

# PRODUCT INFORMATION

## FSG-2 / FSG-2e

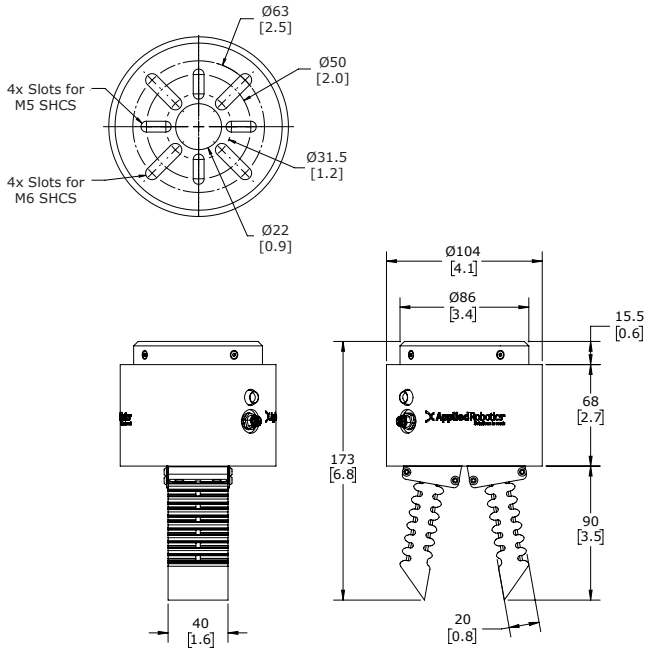

## FSG-4 / FSG-4e

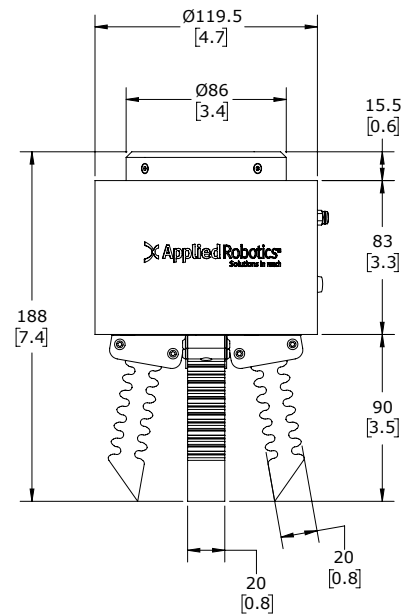

\* Dimensions are in millimeters (inches).  
 \*\* Interface Plate has bolt circle patterns according to ISO 9409-1 specification: 31.5mm, 40mm, 50mm, and 63mm.

# ENHANCED INTELLIGENCE VERSION



The Enhanced Intelligence version of the FSG provides additional finger positions for grip precision and efficiency, as well as force control, allowing the user to reliably handle delicate objects.

The FSG can be easily programmed through a simple user interface that can be accessed with any Wi-Fi enabled device.

FSG-e Specific



Finger Positions	
Position 1 (00) = 0	Position 2 (01) = 2
<input type="text" value="0"/> <input type="button" value="Go"/>	<input type="text" value="2"/> <input type="button" value="Go"/>
Position 3 (10) = -3	Position 4 (11) = 6
<input type="text" value="-3"/> <input type="button" value="Go"/>	<input type="text" value="6"/> <input type="button" value="Go"/>
Force Control	
Part Confirmation: <input type="text" value="400"/> mA	Force Limitation: <input type="text" value="1500"/> mA
<input type="button" value="Set Values"/>	
Finger Calibration	
Finger 1 <input type="button" value="←"/> <input type="button" value="→"/>	Finger 2 <input type="button" value="←"/> <input type="button" value="→"/>



**Applied Robotics, Inc.**  
 648 Saratoga Road, Glenville, NY 12302 USA  
 Tel: +1 518 384 1000  
[www.appliedrobotics.com](http://www.appliedrobotics.com)  
[info@appliedrobotics.com](mailto:info@appliedrobotics.com)

